

Build an Earth's Field Magnetic Observatory!

PART III, FDM Proton Precession Magnetometer Overview

The FDM¹ Proton Precession Magnetometer operates in a conventional manner as was described in PART II of this series of articles. The proton spins of a fluid sample are aligned by a DC solenoid magnetic field. The field is then switched off fast enough to cause a percentage of the protons spins to precess at a frequency representative of the ambient magnetic field. The proton precession causes a tiny electromagnetic field at the precession frequency that is picked up by the previously discharged solenoid coil which now doubles as a receiving antenna. The received signal is amplified by a narrow band low noise amplifier, digitized, and then processed in software using the filter diagonalization method (FDM) to provided a high resolution determination of the precession frequency and hence the ambient magnetic field.

FDM PROTON PRECESSION MAGNETOMETER BLOCK DIAGRAM

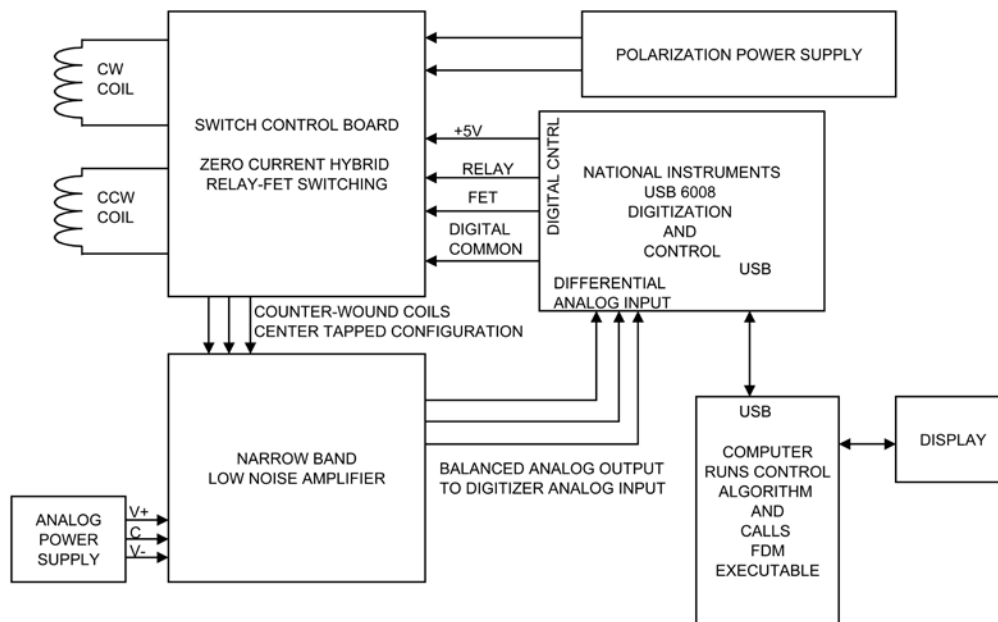

COPYRIGHT © 2010 JOSEPH M. GELLER, All rights reserved.

The block diagram shows an overall view of the FDM magnetometer. The magnetometer has been designed in a modular form to allow for flexibility in replacing modules with newer versions or modules designed by others. The modules or sections include the sensor coils (a pair of counter-wound coils), the switching and control module (a hybrid FET-Relay board), a narrow band low

noise amplifier, a commercial USB 6008 digital output and digitizer module available from National Instruments, and software including an overall control program written in LabVIEW and planned for distribution as a Windows installable program which calls a compiled FDM Windows executable (the frequency estimator described in Part II).



COILS

The coils are wound on 2" PVC pipe sections with threaded cap end pieces which support side walls for 600 turns of #18 wire and multiple layers to give about a 2" coil length.² The two coils are counter-wound. One of the coils is wound clockwise and the other coil of the counter-wound coil pair is wound counter-clockwise. Two wires from each of the coils are fed back into a building from an outdoor coil stand via a shielded four conductor cable. The threaded insert caps are only used in the lower sections of the PVC coil forms (so they rest evenly in a coil holder box). A 125 mL Nalgene specimen bottle is supported using a small spacer, such as can be cut from $\frac{3}{4}$ " plywood with a hole-saw, about even with the powered solenoid coil. Only one of the coils is powered to align the spins of the protons of the liquid in the specimen bottle. The coil pair should be substantially aligned to match the longitudinal solenoid fields of the coils for best cancellation of ambient magnetic field noise. Also, for maximum precession signal strength, the longitudinal axis of the coils should generally be aligned in a horizontal North-South direction, with an elevation angle that places the coil longitudinal axis normal to the local inclination angle. For example, our local

inclination or dip angle is about 70 degrees, and the longitudinal axes of our coils are therefore elevated to about 30 degrees above the horizontal plane. A water resistant automotive connector is used to allow for an easy disconnect of the coil pair for lawn and coil package maintenance. In operation, a heavy white 3 mil trash bag covers the coil sensor package for protection from wind and rain.



COIL STAND

The coil stand was made from standard 2" x 2" pressure treated wood stock and covered with a polyurethane combination stain and sealer. The parts are held together by 3/8" oak dowels.

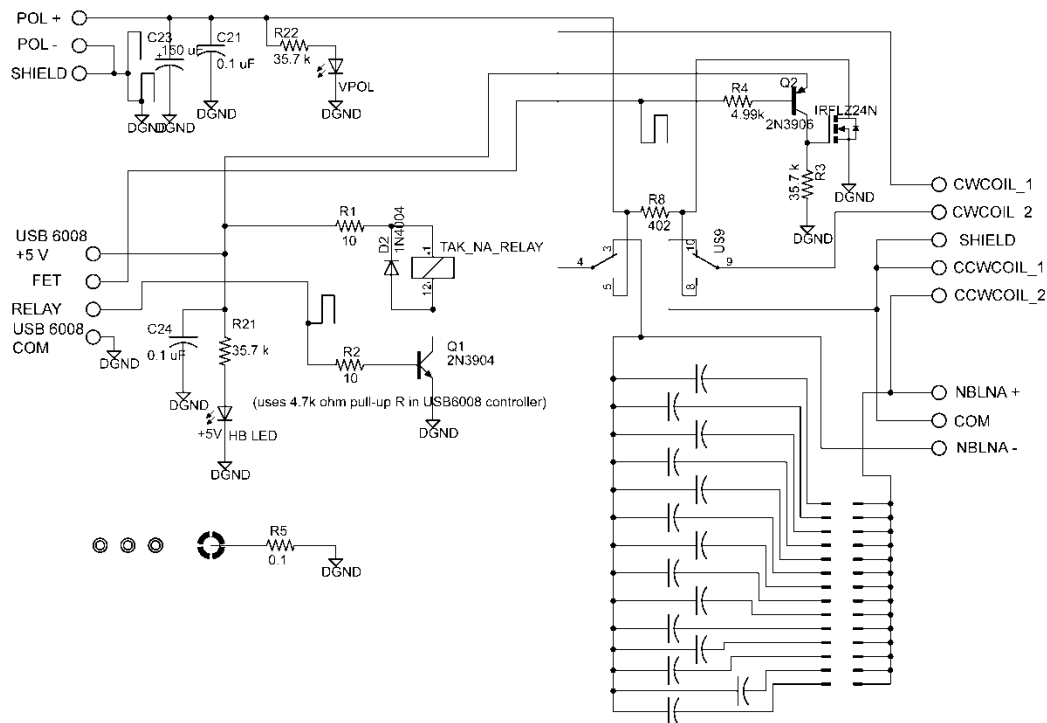

SWITCH CONTROL BOARD & ZERO-CURRENT SWITCHING

Each of the two counter-wound coils is independently fed to the switch control board via a common 4 conductor shielded cable. The powered coil, which can be either one of the coils, is first powered by a DC voltage suitable to cause about a 1.5 A current flow (for a 600 turn coil).

The principle of zero current switching is that the small signal relay with gold plated contacts that configures the coils between a single coil for polarization and a center-tapped pair for reception of the proton precession signal, never changes mechanical state when the powered coil has current flow. Thus, there is no concern with contact arcing or contact pitting from making or breaking an inductive circuit where there is current flow. To achieve zero-current switching, first the relay is closed, then some time later (to allow for mechanical contact chatter to end), a power FET is turned on to apply a voltage across the powered coil, including the wires to it, which causes the polarization current and corresponding solenoid field to align some portion of the protons in the liquid sample. After a pre-determined polarization time, the FET is turned off. When the relay is in the polarization position, a dump resistor of several times the coil and cable resistance is also in parallel with the powered coil. The relay remains in the polarization position until the energy stored in the coil is discharged first by active clamping of the FET in the reverse avalanche mode, cable resistance, and coil resistance combined, then by the dump resistor in combination with the entire load.³ After some time, the relay can then be de-energized to change mechanical state back to the receive mode with no contact arcing. In the receive mode, the two coils are placed in a center-tapped noise cancelling configuration in parallel with a settable fixed capacitance so as to resonate near the average frequency for the average ambient magnetic field. This center-tapped resonant RLC circuit receives and couples the precession signal to the input of the narrow band low noise amplifier.

The desired voltage output for the polarization power supply depends on the combination of the cable resistance, the coil resistance, and the ambient outdoor temperature. Generally 12 V to 15 V is sufficient. For the coils described above, 1.5 A of polarization current provides a sufficient polarization field (~100 Gauss is desirable) over about a 2 second polarization interval. Even with zero-current switching, high quality small signal relays have maximum current ratings that should not be exceeded. 1.5 A is well within that margin for the small signal relay we are using. While not necessary, an automatic cross-over power supply (cross-over from voltage regulation to current regulation during a polarization pulse) is also desirable. With automatic cross-over, setting the

voltage slightly higher than is needed accounting for swings in outdoor temperature, provides the same polarization field for all normal conditions.

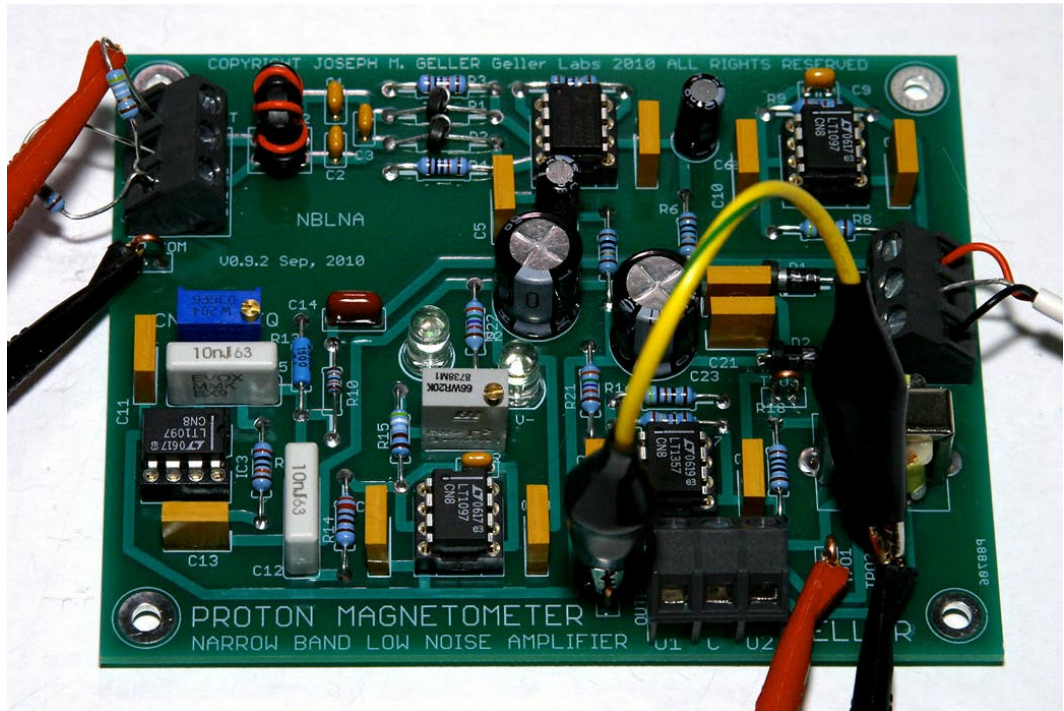
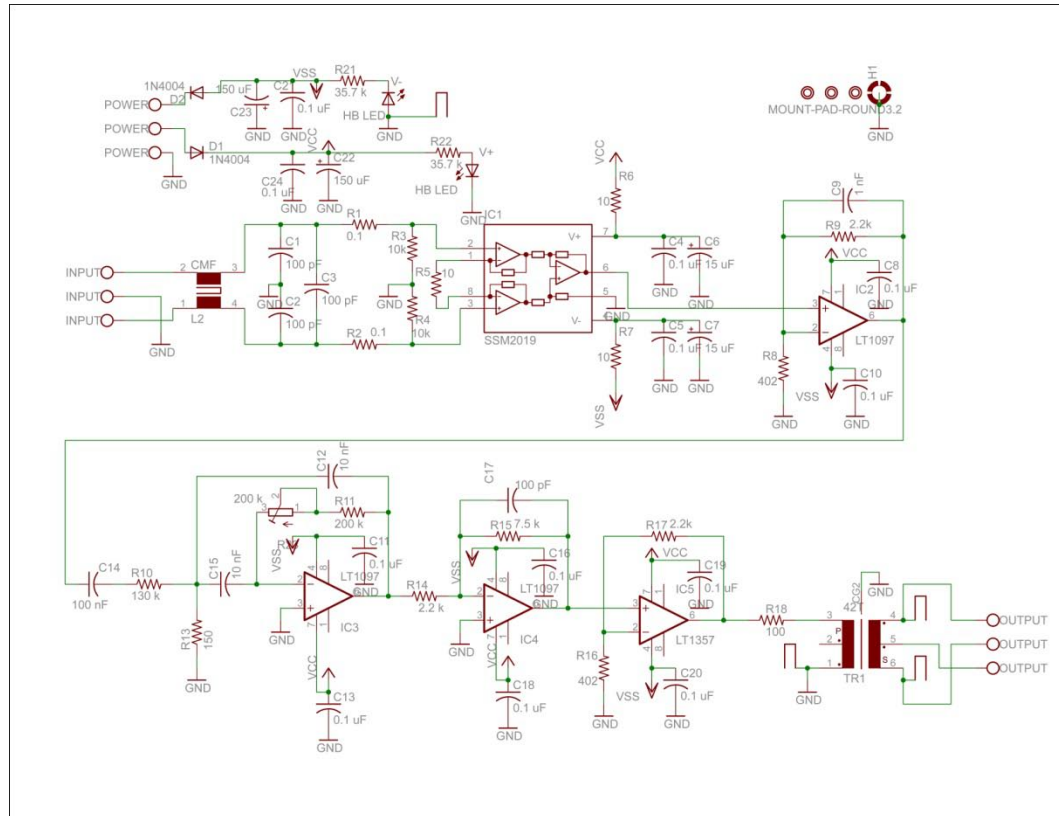

NARROW BAND LOW NOISE AMPLIFIER

The narrow band low noise amplifier receives the precession signal via an input common-mode filter intended to suppress high frequency electromagnetic and radio frequency interference. The overall specifications are an input referred noise of less than 2 nV/rt-Hz, a gain of $\sim 500,000$, and an effective noise bandwidth of less than ~ 200 Hz. Amplification is spread out over many stages to account for the limited open loop gain of each stage. A power output LT1357 stage drives an output transformer helps to isolate the amplifier from successive digitizers and helps to prevent undesirable ground loop currents. The printed circuit board is laid out to minimize inter-stage coupling such as by channeling ground currents, particularly from the input amplifier stage directly to a common power supply ground. A second order multiple feedback bandpass filter is placed early enough in the cascade of gain stages to minimize full amplification of noise and interfering signal energy outside of the desired bandwidth.

The analog power supply provides the V+ and V- rails to the narrow band low noise amplifier. The present design can operate equally well from about 6 V to 12 V power supply rails. Maximum current draw is well under 100 mA. While our R&D was done with a convention hp bench supply, a relatively simple small regulated bipolar power supply can be used. The polarization power supply and the analog power supply commons are connected to a common single point earth ground at the analog power supply.

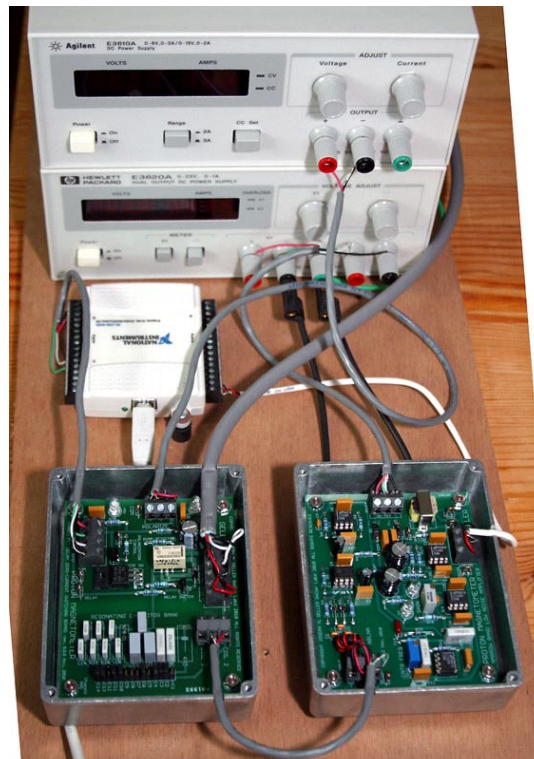

DIGITIZATION AND CONTROL

We chose the National Instruments USB 6008 12-Bit, 10 kS/s Low-Cost Multifunction data acquisition (DAQ) module⁴ for the baseline design. The USB 6008 is particularly convenient, since initial system development was done in the LabVIEW 2010 development environment and we plan to distribute the first version geomagnetic observatory software as a compiled LabVIEW installable application (still under development). The digitizer is configured with a pseudo differential input and runs at the maximum digitization rate of 10 kS/s to help minimize aliasing caused by out of band interfering signals. The exact digitization interval (sample frequency) was measured using a calibrated signal generator, and a calibration constant is applied to realize absolute calibration of the corresponding magnetic field measurement.

CONTROL ALGORITHM AND FDM EXECUTABLE

The control algorithm is a LabVIEW 2010 program. The program provides system timing, data recording, data display, modification of the digitized waveform to emphasize data early in each measurement (exponential apodization) and a call to the FDM executable for each digitized precession signal (also called the free induction decay or FID signal). The FDM executable returns a frequency having a 0.001 Hz resolution, a figure of merit (FOM), and a narrow band signal to noise ratio (NB S/N) for each call. Simultaneously, the LabVIEW program provides a display of the FID waveform envelope from the raw digitized FID signal (before apodization).

The LabVIEW program and FDM executable will be described in more detail later. The FDM executable will be supplied as a Windows callable executable for those who wish to write a control program in another language. A roughly equivalent FDM routine is also available for use in LINUX⁵.

The FORTRAN source code which provided the basis for the our FDM executable (modified for this geomagnetic observatory application) was provided for this project by Professor Mandelshtam, the author of a landmark paper⁶ describing a new approach to harmonic inversion for use in NMR spectroscopy. The original FORTRAN source code will not be distributed at this time.

There are other commercially available digitization and control modules similar to the USB 6008 or other experimenters might use a custom ADC circuit

to perform digitization. Other options include providing a different switching scheme and/or using custom software. Some experimenters have expressed an interest in other coil configurations or in using our experiment as a starting point for later exploration of other types of proton magnetometers.

While there are certainly many other viable designs, we continue this series of construction articles using our baseline design. Updated project documentation is available at our website⁷.

In Part IV of this series of articles, we will present a more detailed description of the construction of the counter-wound coils and the coil stand. Day to day notes on the project and representative magnetograms are also generally posted in our journal notes⁸.

A Yahoo discussion group has been established to discuss this project as well as magnetometers in general as relevant to Earth's magnetic field observations⁹.

¹ Filter Diagonalization Method "FDM" (harmonic inversion).

² A 2.5" long coil with about 686 turns has also been used.

³ See the December 20 journal notes, and comments on the SWCTRL BOARD and The COIL ENERGY DUMP <http://www.gellerlabs.com/PMAG%20Coil%20Dump.htm> for more details and oscillographs illustrating the energy dump process.

⁴ <http://sine.ni.com/nips/cds/view/p/lang/en/nid/201986> , also generally available used on eBay from ~\$80 to \$150.

⁵ <http://ab-initio.mit.edu/harminv/> (if this link fails, just Google™ "harminv")

⁶ Vladimir A. Mandelshtam, Howard S. Taylor, Harmonic inversion of time signals and its applications, Journal of Chemical Physics (1997), Volume 107, Issue 17, 1997, Pages 6756-6769.

⁷ <http://www.gellerlabs.com/PMAG%20Docs.htm> .

⁸ <http://www.gellerlabs.com/PMAGThoughts.htm> .

⁹ <http://tech.groups.yahoo.com/group/protonmagnetometer/> .